

SIXTIESMANIA

Performance and Backline Equipment Rider

For more information contact Andrew Hill at (702) 501-6626 or sixtiesmania@yahoo.com

Page 1 of 3

The following are performance and backline equipment requirements for the members of "Sixtiesmania". The backline equipment portion of this rider will only be in effect when the purchaser is providing backline equipment.

These additional requirements will be agreed to by both parties and shall be binding in an addition to all other signed performance contracts. They shall also be in accordance with the attached stage plot requirements.

This is for a performance to take place on _____, by and between Sixtiesmania, hereinafter referred to as "PERFORMERS" and _____, hereinafter referred to as "PURCHASER".

Purchaser shall initial next to each applicable item on the rider to show purchaser's approval and acceptance. Please put N/A on any non-applicable items. In lieu of providing certain equipment or if the required equipment is not available, PURCHASER can instead, chose to provide compensation for airline luggage fees.

Stage/Performance Area

Stage *Initials_____

The performance area needs to be a minimum of 25 ft long by 15 feet deep and 2 feet high. If the stage at the venue is built using individual riser sections it is the responsibility of the PURCHASER to make sure that the performance area is stable and secure. Each side of the stage should have a clear path marked with white tape for artist's entrance and exit. If the performance area is on risers then stairs must be provided on both sides of the performance area. There must also be a changing room backstage within a reasonable distance for the band to make costume changes.

Sound Requirements *Initials_____

PURCHASER shall provide a professional and complete sound system with operators. System is to provide full coverage of the venue without distortion or overload of any kind and be able handle the mixing of all instruments and vocals clearly. Monitor system must be capable of providing separate mixes for each band member as per the stage plot layout.

Sound company must be able to accommodate 5 total monitor mixes as listed on the stage plot. The sound company shall provide background music when PERFORMERS are not on stage. Sound company will provide ALL microphones, microphone stands and direct boxes for all backline instruments (see input list on stage plot for assignments).

SIXTIESMANIA

Performance and Backline Equipment Rider

For more information contact Andrew Hill at (702) 501-6626 or sixtiesmania@yahoo.com

Page 2 of 3

Vocal Requirements *Initials_____

- Five (5) microphones for vocals (Shure SM58 or BETA 58) will be provided by PURCHASER.

Lighting and Effects *Initials_____

A professional motion lighting system with a minimum of 5 colors as well as white lights, capable of even, full stage coverage is required, as well as a professional lighting control board run by an experienced lighting director. Use of a water-based fog machine and other special effects is highly encouraged for a high quality show.

Other *Initials_____

Sixtiesmania has a banner which requires at least one person to install.

Equipment:

Guitar *Initials_____

- 2 x Fender quality combo guitar amplifiers
- 5 x good quality guitar stands
- 4 x 20 foot guitar cables

Bass *Initials_____

- 1 x Gallien Kruger 700RB-II bass head or equivalent
- 1 x Gallien Kruger 4x10 800W bass speaker cabinet or equivalent

Drums *Initials_____

DW, Yamaha, Tama Drum Kit or equivalent, consisting of the following:

- 1 x 22" Kick Drum
- 1 x 16" Floor tom leg mounted
- 1 x 12" Rack tom, mounted on a double stand
- 1 x 14" x 6" Snare drum
- 1 x Kick pedal
- 1 x Crash cymbal
- 1 x Ride cymbal
- 1 x pair of 14" medium hi-hat cymbals
- 1 drum throne
- All cymbal stands and hardware
- "As New" drum skin

SIXTIESMANIA

Performance and Backline Equipment Rider

For more information contact Andrew Hill at (702) 501-6626 or sixtiesmania@yahoo.com

Page 3 of 3

Keyboards *Initials_____

- 1 x Roland XP-80 keyboard
- 1 x Roland XP-60 or a second Roland XP-80 keyboard
- 1 x Two tier keyboard quick lock stand
- 1 x Adjustable keyboard seat 1 - Roland 2 or 3 channel amp
- 1 x Midi cable
- 1 x Sustain pedal

Stage Arrangements *Initials_____

Stage Input List

1. VOX 1
2. VOX 2
3. VOX 3
4. VOX 4
5. VOX 5
6. KEYS 1
7. KEYS 2
8. TRACKS - DI
9. AMP 1 Guitar Amp – Mic
10. AMP 2 Guitar Amp – Mic
11. Bass Amp – DI
12. Kick Drum
13. Snare
14. Rack 1
15. Floor Tom
16. Hi Hats
17. Drum Overhead Left
18. Drum Overhead Right
19. Audience Ambient Mic if using in-ears.
20. Audio Playback from FOH, voice overs

Stage Layout

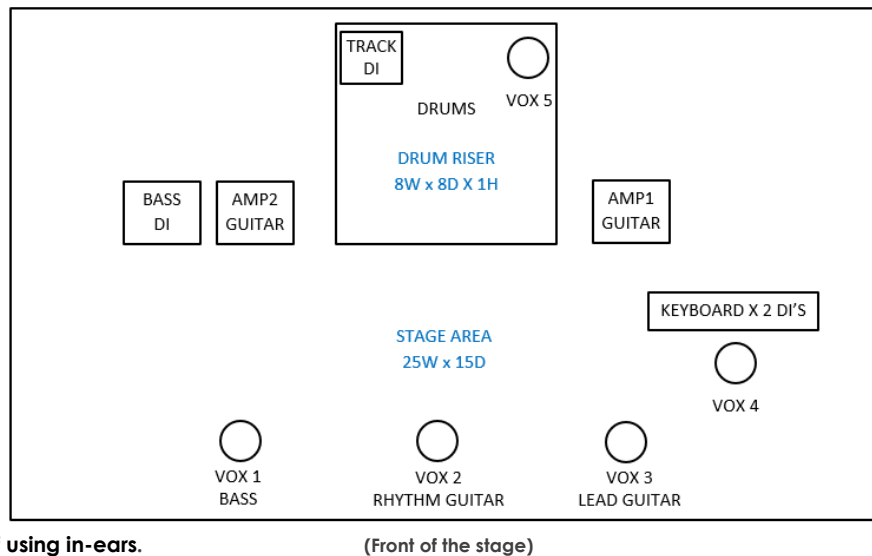

Soundcheck *Initials_____

Please allow a minimum of 1 (one) hour up to a 2 (two) hour soundcheck.
All equipment must be set up and ready by agreed soundcheck time.

PURCHASER

Signature: _____

Name: _____

Date: _____

SIXTIESMANIA

Signature: _____

Name: _____

Date: _____